

Model: LTC-0630F

- ▶ Recommended payload ≤ 650kg
- ▶ Locking force: 72930N Allowable static moment: 5000N·m Allowable static torque: 5000N·m
- ▶ 4 available module interfaces
- ▶ Air pressure lost self locking function, the master plate and tool plate won't be separated even the air pressure in master plate lost accidentally.
- ▶ Master plate with locking/unlocking sensor and tool-in-position sensor



Specifications

Model	Master plate	LTC-0630FM
	Tool plate	LTC-0630FT
Load	Payload capacity	650kg
	Locking force	72930N
	Allowable static bending moment	5000N·m
	Allowable static torque	5000N·m
Size and precision	Dimension	210*210mm
	Combined thickness	100mm
	Position repeatability	0.015mm
Air pressure for working		0.4~0.8Mpa

Item No.	Master plate item No.	0172
	Tool plate item No.	0173
Material	Main body	Aluminum alloy
	Locking mechanism	Alloy steel
Locking mechanism		Locking steel ball
Work environment	Temperature	0-60°C
	Humidity	0-95%
Weight	Master side	10.6kg
	Tool side	4.35kg

Dimensions

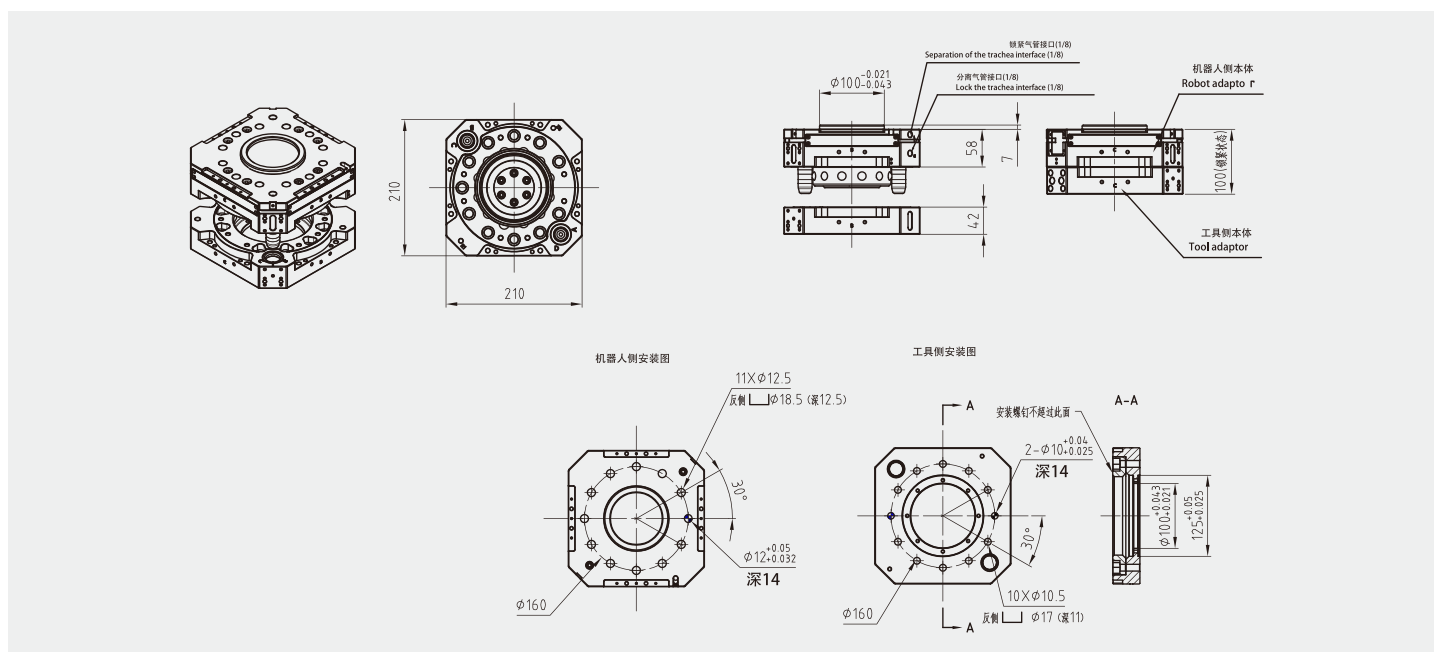



Adapter module

Type	Photo	Model	Item No.	Description	Interface No.	
Sensor		PNP	LMO-P4-01	1563	Locking/Unlocking sensor	A
		NPN	LMO-N4-01	1568		
Industrial Bus module		Mater side	LMO-C28-BM01-AF03-M	1975	7/8-5Pins electrical power male connector, M12-4Pins D-code female connector	A
		Tool side	LMO-C28-BM01-AF03-T	1976		
		Tool side	LMO-C28-BM00-AF03-T	1977	Safety docking interface, integrated tool-ID.	A
		Mater side	LMO-C28-S01A-BI01-SN02-AF03-M	2110	7/8-5Pins electrical power male connector, M12-4Pins D-code female connector, 25D male connector.	
		Tool side	LMO-C28-S01A-BI01-SN00-AF03-T	2111	7/8-5Pins electrical power male connector, M12-4Pins D-code female connector, 25D male connector, safety docking interface, integrated tool-ID.	
		Tool side	LMO-C28-S01A-BI00-SN02-AF03-T	2112	25D female connector, safety docking interface, integrated tool-ID.	
High Electrical power module		Mater side	LMO-E03KM	1009	3 core 150A cold-press terminal	D
		Tool side	LMO-E03KT	1010		
		Mater side	LMO-E03FM	0385	3 core 150A with high currency connector	D
		Tool side	LMO-E03FT	0386		
		Mater side	LMO-E03QM	1088	3 core 400A cold-press terminal	D
		Tool side	LMO-E03QT	1089		
		Mater side	LMO-E01F-M	2105	1 core 400A cold-press terminal	D
		Tool side	LMO-E01F-T	2106		
Servo spot welding module		Mater side	LMO-C33-SM04C-MS14-M	1301	Fanuc Servo Module, 20-17P Servo connector, 20-29P Servo connector, 20-27P signals connector.	C
		Tool side	LMO-C33-SM04C-MS14-T	1302	Fanuc Servo Module, 20-17S Servo connector, 20-29S Servo connector, 20-27S signals connector.	
		Mater side	LMO-C33-SM01C-MS10-M	1307	ABB Servo Module, 10B (8+12+25) pins connector	C
		Tool side	LMO-C33-SM01C-MS10-T	1308	ABB Servo Module, 10B (8+12+25) pins connector	
		Mater side	LMO-C33-SM02C-MS14-M	1303	KUKA Servo Module, M23-6Pins electrical power male connector, M23-12Pins male Servo connector, 20-27P signals connector.	C
		Tool side	LMO-C33-SM02C-MS14-T	1304	KUKA Servo Module, M23-6Pins electrical power female connector, M23-12Pins female Servo connector, 20-27S signals connector.	
		Mater side	LMO-C33-SM03C-MS09-M	1305	YASKAWA Servo Module, 20-15P Servo connector, 20-29P Servo connector, 22-19P signals connector.	C
		Tool side	LMO-C33-SM03C-MS09-T	1306	YASKAWA Servo Module, 20-15S Servo connector, 20-29S Servo connector, 22-19S signals connector.	

Type	Photo	Model	Item No.	Description	Interface No.	
Air&fluid module		/	LMO-L03N-03-Q	1421	PT1/2, optional 1-3 ports	B
			/	LMO-L05F-05-Q	1418	
Welding guns&SPR module		Mater side	LMO-C53B-SM22-MS12-SM02C-MS14-M	1980	Welding guns ⇕ SPR	B, C, D
		Tool side	LMO-C53B-SM02C-MS14-T	1981		
		Tool side	LMO-C53B-SM22-MS12-T	1982		
SPR FDS module		Mater side	LMO-C53B-SM22-MS12-SM02C-BI01-M	1983	SPR ⇕ FDS	B, C, D
		Tool side	LMO-C53B-SM22-MS12-T	1982		
		Tool side	LMO-C53B-SM02C-BI01-T	1984		
Grounding module		Mater side	LMO-630F-PE-M	1964	Used for shielding and grounding protection, 75A/55VAC	A
		Tool side	LMO-630F-PE-T	1965		
Nail module		Mater side	LMO-GD01M	5057	Stud interface for SPR or FDS installation, customized.	B, C, D
		Tool side	LMO-GD01T	5058		
Solenoid Valve Module		Mater side	LMO-SOL-A6-S12-C	1911	Integrated double solenoid valves, the air pressure detection is included.	A
Safety docking components		Tool side	LMO-DS01-C	0899	Plunger type.	A
		Tool side	LMO-DS01-A	0880	Insert type.	A
Hydraulic Module		Mater side	LMO-YL02A-M	1427	16MPa *2	B, C, D
		Tool side	LMO-YL02A-T	1428	16MPa *2	
		Mater side	LMO-YL02B-M	1429	25MPa *2	B, C, D
		Tool side	LMO-YL02B-T	1430	25MPa *2	