

# Model: LTC-0120C

- ▶ Recommended payload ≤ 120kg
- ▶ Locking force: 15407N Allowable static moment: 842N·m Allowable static torque: 1200N·m
- ▶ With 10 x PT1/8 air ports, 2 available module interfaces
- ▶ Suitable for handling, palletizing, welding, polishing, deburring
- ▶ Air pressure lost self locking function, the master plate and tool plate won't be separated even the air pressure in master plate lost accidentally.
- ▶ Master plate with locking/unlocking sensor and tool-in-position sensor



## Specifications

Model	Master plate	LTC-0120CM	Item No.	Master plate item No.	0137
	Tool plate	LTC-0120CT		Tool plate item No.	0237
Load	Payload capacity	120kg	Material	Main body	Aluminum alloy
	Locking force	15407N		Locking mechanism	Alloy steel
	Allowable static bending moment	842N·m	Locking mechanism	Locking steel ball	
	Allowable static torque	1200N·m			
Size and precision	Dimension	Φ168mm	Work environment	Temperature	0-60°C
	Combined thickness	83mm		Humidity	0-95%
	Position repeatability	±0.02mm	Weight	Master side	2.28kg
Air pressure for working	0.4~0.7Mpa	Pneumatic port		10 x PT1/8	Max pressure

## Dimensions

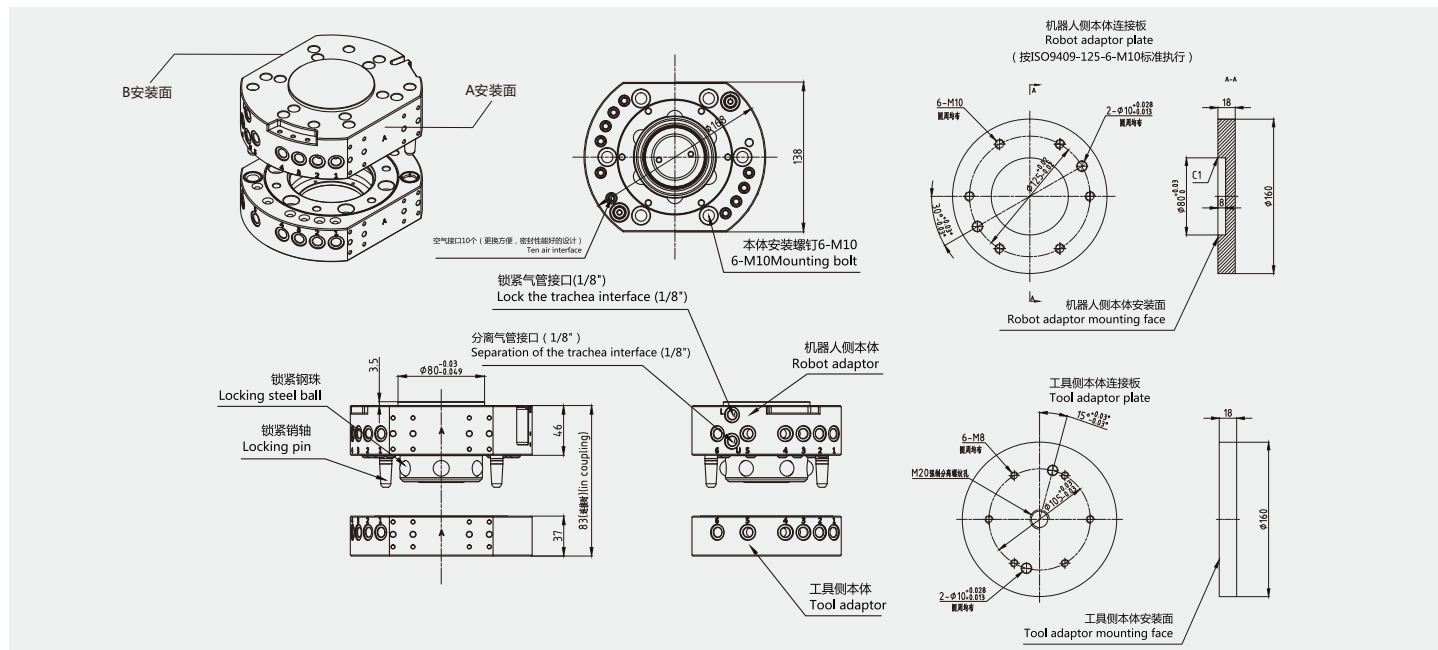

## Adapter module

Type	Photo	Model	Item No.	Description	Interface No.	
Sensor		PNP	LMO-P3-01	1562	Locking/Unlocking sensor and tool-in-position sensor LED status visible	A
		NPN	LMO-N3-01	1567		
Electrical module		Master side	LMO-E16-MS07A-AF01-M	0357	5A x 7pins Tool-ID identify	A
		Tool side	LMO-E16-MS07A-AF01-T	0358		
		Master side	LMO-F21-MS15A-AF01-M	0393	5A x 15pins Tool-ID identify	A
		Tool side	LMO-F21-MS15A-AF01-T	0394		
		Master side	LMO-F21-S34A-AF01-M	0558	5A x 34pins Tool-ID identify	A
		Tool side	LMO-F21-S34A-AF01-T	0559		
		Master side	LMO-E12-S19A-M	0361	3A x 19pins	B
		Tool side	LMO-E12-S19A-T	0362		
		Master side	LMO-F22-S38A-M	0579	3A x 38pins	B
		Tool side	LMO-F22-S38A-T	0580		
		Master side	LMO-F21-E06A-S15-AF01-M	0539	20A x 6pins 3A x 15pins Tool-ID identify	A
		Tool side	LMO-F21-E06A-S15-AF01-T	0540		
	Master side	LMO-E12-E06A-M	0507	20A x 16pins	B	
	Tool side	LMO-E12-E06A-T	0508			
	Master side	LMO-F22-E06A-E06A-M	0563	20A x 12pins	B	
	Tool side	LMO-F22-E06A-E06A-T	0564			
Industrial Bus module		Master side	LMO-F21-S13-BI01-AF01-M	0545	Ethernet, EtherNet P, EtherCAT, Profinet Industrial Bus module M12 4pins D-encoder Industrial bus interface	A
		Tool side	LMO-F21-S13-BI01-AF01-T	0546		
		Master side	LMO-F21-S13-BI03-AF01-M	0553	Devicenet Industrial Bus module M12 4pins A-encoder Industrial bus interface	A
		Tool side	LMO-F21-S13-BI03-AF01-T	0554		
		Master side	LMO-E12-BI15-M	0310	Ethernet Industrial Bus module RJ45 connector	B
		Tool side	LMO-E12-BI15-T	0311		
Air&fluid module		Master side	LMO-F22-SM10C-M	0561	20A x 4pins 2pins brake 8pins encoder signal	B
		Tool side	LMO-F22-SM10C-T	0562		
		Master side	LMO-E14-U02A-M	0601	5A 1.4KV Single channel HF module	B
		Tool side	LMO-E14-U02A-T	0602		
		Master side	LMO-E13-U02A-U02A-M	0659	5A 1.4KV Dual-channel HF module	B
		Tool side	LMO-E13-U02A-U02A-T	0660		
		Master side	LMO-GC02AM	0477	2 x PT3/8 Open air port	B
		Tool side	LMO-GC02AT	0478		
		Master side	LMO-GC04AM	0479	4 x PT3/8 Open air port	B
		Tool side	LMO-GC04AT	0480		
		Master side	LMO-GC06AM	0481	6 x PT1/8 Open air port	B
		Tool side	LMO-GC06AT	0482		
	Master side	LMO-GC10AM	0625	10 x PT1/8 Open air port	B	
	Tool side	LMO-GC10AT	0626			
	Master side	LMO-GS01AM	1212	1 x PT3/8 Self-sealing air port	B	
	Tool side	LMO-GS01AT	1213			
	Master side	LMO-GS02BM	1216	2 x PT3/8 Self-sealing air port	B	
	Tool side	LMO-GS02BT	1217			
	Master side	LMO-GS04AM	1220	4 x PT3/8 Self-sealing air port	B	
	Tool side	LMO-GS04AT	1221			
	Master side	LMO-L01BM	1201	1 x PT1/2 Self-sealing air port or water path	B	
	Tool side	LMO-L01BT	1205			
	Master side	LMO-L02BM	1206	2 x PT1/2 Self-sealing air port or water path	B	
	Tool side	LMO-L02BT	1207			