

Model: LTC-0070B

- ▶ Recommended payload ≤ 70kg
- ▶ Locking force: 9973N Allowable static moment: 328.5N·m Allowable static torque: 451N·m
- ▶ With 6 x PT1/8 air ports, 4 available module interfaces
- ▶ Suitable for handling, palletizing, welding, polishing, deburring
- ▶ Air pressure lost self locking function, the master plate and tool plate won't be separated even the air pressure in master plate lost accidentally.
- ▶ Master plate with locking/unlocking sensor and tool-in-position sensor



Specifications

Model	Master plate	LTC-0070BM	Item No.	Master plate item No.	0149
	Tool plate	LTC-0070BT		Tool plate item No.	0249
Load	Payload capacity	70kg	Material	Main body	Aluminum alloy
	Locking force	9973N		Locking mechanism	Alloy steel
	Allowable static bending moment	328.5N·m	Locking mechanism	Locking steel ball	
	Allowable static torque	451N·m			
Size and precision	Dimension	Φ138mm	Work environment	Temperature	0-60°C
	Combined thickness	74mm		Humidity	0-95%
	Position repeatability	±0.02mm	Weight	Master side	1.83kg
Air pressure for working	0.4~0.7Mpa	Air connector		Pneumatic port	6 x PT1/8
			Max pressure	0.8Mpa	

Dimensions

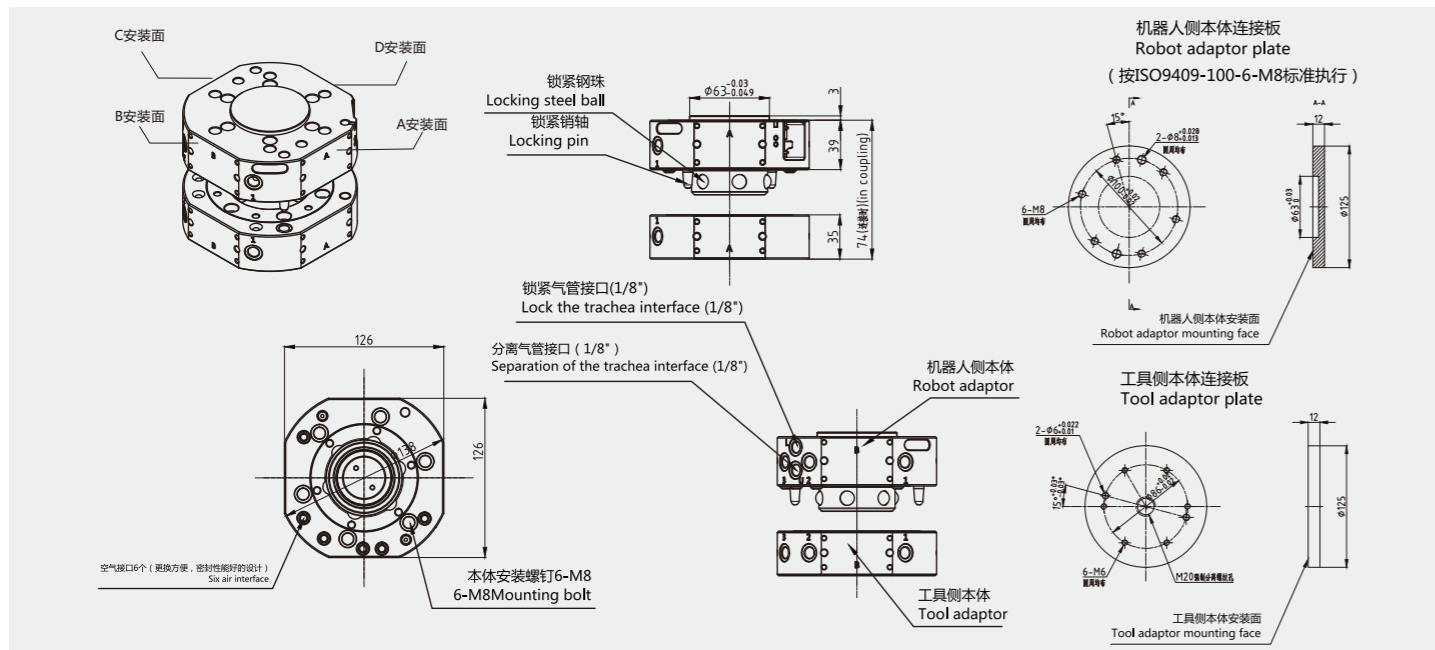

Adapter module

Type	Photo	Model	Item No.	Description	Interface No.	
Sensor		PNP	LMO-P3-01	1562	Locking/Unlocking sensor and tool-in-position sensor LED status visible	A
		NPN	LMO-N3-01	1567		
Electrical module		Master side	LMO-E16-MS07A-AF01-M	0357	5A x 7pins Tool-ID identify	A
		Tool side	LMO-E16-MS07A-AF01-T	0358		
		Master side	LMO-E16-S15A-AF01-M	0359	3A x 15pins Tool-ID identify	A
		Tool side	LMO-E16-S15A-AF01-T	0360		
		Master side	LMO-E16-S22-AF01-M	0589	3A x 22pins Tool-ID identify	A
		Tool side	LMO-E16-S22-AF01-T	0590		
		Master side	LMO-E12-S19A-M	0361	3A x 19pins	B, C, D
		Tool side	LMO-E12-S19A-T	0362		
		Master side	LMO-E12-S26-M	0595	3A x 26pins	B, C, D
		Tool side	LMO-E12-S26-T	0596		
		Master side	LMO-E12-E06A-M	0507	20A x 6pins	B, C, D
		Tool side	LMO-E12-E06A-T	0508		
	Master side	LMO-E11-S05-BI01-AF01-M	1113	Ethernet, EtherNet P, EtherCAT, Profinet Industrial Bus module M12 4pins D-encoder Industrial bus interface	A	
	Tool side	LMO-E11-S05-BI01-AF01-T	1114			
	Master side	LMO-E11-BI01-AF01-M	0635	Ethernet, EtherNet P, EtherCAT, Profinet Industrial Bus module M12 4pins D-encoder Industrial bus interface	A	
	Tool side	LMO-E11-BI01-AF01-T	0636			
	Master side	LMO-E12-BI01-M	0333	Ethernet, EtherNet P, EtherCAT, Profinet Industrial Bus module M12 4pins D-encoder Industrial bus interface	B, C, D	
	Tool side	LMO-E12-BI01-T	0334			
	Master side	LMO-E11-BI02-AF01-M	0641	Devicenet Industrial Bus module M12 5pins Industrial bus interface	A	
	Tool side	LMO-E11-BI02-AF01-T	0642			
	Master side	LMO-E11-BI03-AF01-M	0643	CC-Link Industrial Bus module M12 4pins A-encoder Industrial bus interface	A	
	Tool side	LMO-E11-BI03-AF01-T	0644			
	Master side	LMO-E11-S07-BI03-AF01-M	0645	CC-Link Industrial Bus module M12 4pins A-encoder Industrial bus interface	A	
	Tool side	LMO-E11-S07-BI03-AF01-T	0646			
	Master side	LMO-E12-BI05-M	0331	Gigabit Ethernet Industrial Bus module M12 8pins X-encoder Industrial bus interface	B, C, D	
	Tool side	LMO-E12-BI05-T	0332			
	Master side	LMO-E12-BI15-M	0310	Ethernet Industrial Bus module RJ45 connector	B, C, D	
	Tool side	LMO-E12-BI15-T	0311			
	Master side	LMO-E13-SM10B-M	0509	4 x 12A power supply 2pins x 3A brake 10pins encoder signal	B, C, D	
	Tool side	LMO-E13-SM10B-T	0510			
	Master side	LMO-E14-U02A-M	0601	5A 1.4KV Single channel HF module	B, C, D	
	Tool side	LMO-E14-U02A-T	0602			
	Master side	LMO-E13-U02A-U02A-M	0659	5A 1.4KV Dual-channel HF module	B, C, D	
	Tool side	LMO-E13-U02A-U02A-T	0660			
	Master side	LMO-GC02AM	0477	2 x PT3/8 Open air port	B, C, D	
	Tool side	LMO-GC02AT	0478			
	Master side	LMO-GC06AM	0481	6 x PT1/8 Open air port	B, C, D	
	Tool side	LMO-GC06AT	0482			
	Master side	LMO-GC10AM	0625	10 x PT1/8 Open air port	B, C, D	
	Tool side	LMO-GC10AT	0626			
	Master side	LMO-GS01AM	1212	1 x PT3/8 Self-sealing air port	B, C, D	
	Tool side	LMO-GS01AT	1213			
	Master side	LMO-GS03AM	1218	3 x PT3/8 Self-sealing air port	B, C, D	
	Tool side	LMO-GS03AT	1219			
	Master side	LMO-L01BM	1201	1 x PT1/2 Self-sealing air port or water path	B, C, D	
	Tool side	LMO-L01BT	1205			